

# INSTALLATION INSTRUCTIONS MANUAL

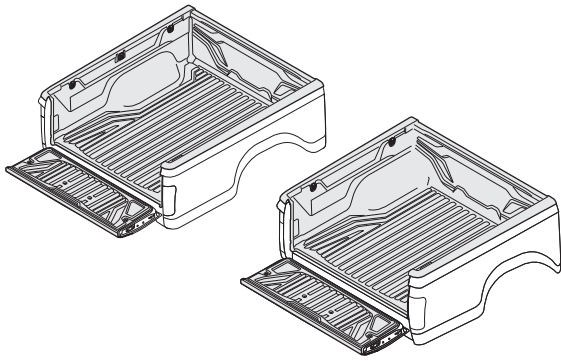

## Caution for installation

Read this mounting manual carefully, before your start the installation.

1. Area where to install product should be clean.
2. During installation, person who installed should take off any ornaments.

<b>Product name</b>	BED LINER O/R
<b>Model name</b>	ISX D-MAX CAB/DBC 2020
<b>Inst. number</b>	L03-1584

## Component parts

<b>CAB</b> 	<b>DBC</b> 	<b>1</b>  x1	<b>2</b>  x1	<b>3</b>  CAB x6 / DBC x4	<b>4</b>  x4
<b>Torque used for Lock set</b>	 U-lock Torque 3.0 ± 1.0 Nm.	 Super lock S13 Torque 4.0 ± 1.0 Nm.	 Super lock S17 Torque 9.0 ± 1.0 Nm.	 Super lock S20 Torque 9.0 ± 1.0 Nm.	

## Tools used

--	--	--	--

## Instruction procedure (Install the same in both versions)

**1**

**2 CAB**

**Super lock**  
**CASE 1**  
Super lock=6  
U-lock=6

**Super lock**  
**CASE 2**  
Super lock=4  
U-lock/S13=2

**DBC**

**3**

**\*\*Please see Torque used for Lock set\*\***

**4**

x3  
20-30 mm.

**5**

Double side tape